

(12) INTERNATIONAL APPLICATION PUBLISHED UNDER THE PATENT COOPERATION TREATY (PCT)

(19) World Intellectual Property Organization
International Bureau



(43) International Publication Date
31 January 2002 (31.01.2002)

PCT

(10) International Publication Number
WO 02/08750 A1

(51) International Patent Classification⁷: G01N 33/487

(21) International Application Number: PCT/GB01/03208

(22) International Filing Date: 17 July 2001 (17.07.2001)

(25) Filing Language: English

(26) Publication Language: English

(30) Priority Data:
0017738.6 20 July 2000 (20.07.2000) GB

(71) Applicant: HYPOGUARD LIMITED [GB/GB]; Dock Lane, Melton, Suffolk IP12 1PE (GB).

(72) Inventor: BLACK, Murdo, M.; High Trees, Shaw Valley Road, Martlesham, Ipswich IP12 4SH (GB).

(74) Agents: GEMMELL, Peter, Alan et al.; Dummett Copp, 25 The Square, Martlesham Heath, Ipswich IP5 3SL (GB).

(81) Designated States (national): AE, AG, AL, AM, AT, AU, AZ, BA, BB, BG, BR, BY, BZ, CA, CH, CN, CO, CR, CU,

CZ, DE, DK, DM, DZ, EC, EE, ES, FI, GB, GD, GE, GH, GM, HR, HU, ID, IL, IN, IS, JP, KE, KG, KP, KR, KZ, LC, LK, LR, LS, LT, LU, LV, MA, MD, MG, MK, MN, MW, MX, MZ, NO, NZ, PL, PT, RO, RU, SD, SE, SG, SI, SK, SL, TJ, TM, TR, TT, TZ, UA, UG, UZ, VN, YU, ZA, ZW.

(84) Designated States (regional): ARIPO patent (GH, GM, KE, LS, MW, MZ, SD, SL, SZ, TZ, UG, ZW), Eurasian patent (AM, AZ, BY, KG, KZ, MD, RU, TJ, TM), European patent (AT, BE, CH, CY, DE, DK, ES, FI, FR, GB, GR, IE, IT, LU, MC, NL, PT, SE, TR), OAPI patent (BF, BJ, CF, CG, CI, CM, GA, GN, GQ, GW, ML, MR, NE, SN, TD, TG).

Published:

- with international search report
- before the expiration of the time limit for amending the claims and to be republished in the event of receipt of amendments

For two-letter codes and other abbreviations, refer to the "Guidance Notes on Codes and Abbreviations" appearing at the beginning of each regular issue of the PCT Gazette.



WO 02/08750 A1

(54) Title: TEST MEMBER

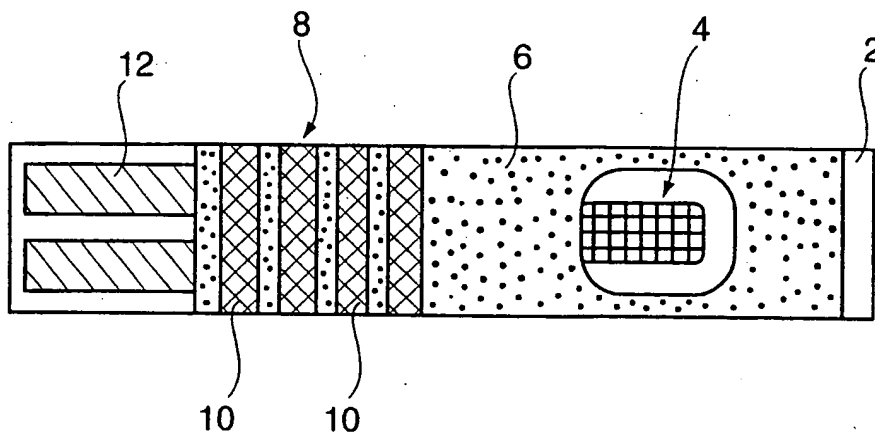

(57) Abstract: A test member suitable for use in a test device for testing of analyte concentration in a fluid to be applied thereto comprises a base member (2) having a working area (4) to which the fluid is to be applied, containing a reagent which is reactive to the said analyte to produce an electrical signal or a colour change, and a non-working area (8) adjacent to the working area (4). The total thickness of the test member in at least a portion of the non-working area (8) is at least as great as the total thickness of the test member in the working area (4). The invention also provides a test device which includes a stack of the test members.

TEST MEMBER

BACKGROUND OF THE INVENTION

5 1. Field of the Invention

The present invention relates to a test member for measuring the concentration of an analyte in a fluid sample, notably to a test strip for analysing blood glucose or other analytes in bodily fluids. The invention
10 also provides a test device which includes a stack of the test members.

2. Background of the Invention

15

Diabetics regularly need to test samples of their blood to determine the level of blood glucose. The results of such tests may be used to determine levels of medication needed to treat the diabetes at the time. In one known type of
20 system, disposable sensors are used to test the blood. The sensors typically take the form of test strips which are provided with a reagent material that will react with blood glucose to produce an electrical signal. Conductive tracks on the test strip relay the electrical signal to a
25 meter which displays the result. After a sample of blood has been applied to the test strip and the measurement has been taken, the test strip is disposed of. In order to couple the conductive tracks on a test strip with the
30 holder prior to the start of testing. The sensor holder has corresponding electrodes which are brought into electrical contact with the conductive tracks of the test

- 2 -

strip. Alternatively, the reagent in the test strip may undergo a visible colour change, the magnitude of which is used to determine the analyte concentration in the applied fluid.

5

It is known to provide a stack of disposable circular test elements in a cylindrical housing, the stack being urged towards a test station by a spring to form a liquid-proof seal, for example as described in WO 94/10558.

10

A problem with providing disposable test members in a stack is that the working area to which the fluid sample will be applied can become scuffed, particularly when a compressive force is applied to the stack by a spring.

15

It is an object of the present invention to provide an improved test member suitable for use in test devices that employ test members in a stack.

20 SUMMARY OF THE INVENTION

According to an aspect of the present invention there is provided a test member suitable for use in a test device for testing of analyte concentration in a fluid to be
25 applied thereto, the test member comprising a base member having a working area to which the fluid is to be applied, containing a reagent which is reactive to the said analyte to produce an electrical signal or a colour change, and a
30 non-working area adjacent to the working area, wherein the total thickness of the test member in at least a portion of the non-working area is at least as great as the total thickness of the test member in the working area.

By making the non-working area at least as thick as the working area, scuffing or abrasion of the working area in a stack can be reduced. Moreover, if a compressive load is applied to a stack of the test members, this may be spread out over a greater area, thereby reducing the possibility of compressive damage to the working area.

In a preferred embodiment, at least a part of the non-working area is of greater total thickness than the thickness of the working area. This further reduces the likelihood of damage to the working area by scuffing or abrasion when in a stack. The difference in thickness is preferably from 1 to 20 μm , notably from 5 to 10 μm .

The test member may be of any desired shape for a particular application; however, typically the test member will be an elongate test strip. For convenience hereinafter, the invention will be described with reference to such a test strip. However, it is to be understood that the invention is not limited to this embodiment.

In one embodiment, the reagent is reactive to the analyte to produce a visible colour change. Alternatively, the reagent may react with the analyte to produce an electrical signal which is measured and displayed by a meter. In this embodiment, the working area has electrodes which are electrically connected to electrode tracks in the non-working area, and at least part of the tracks are exposed for connection to electrodes of a meter. The invention will be described hereinafter with

reference to this embodiment.

To build up the working area, a plurality of layers are sequentially applied to the base layer, for example by
5 screen printing, typically with curing or drying steps between the application steps. The layers which are printed typically comprise electrode patterns, a reagent layer, and a mesh layer (for spreading out an applied fluid). As a result of the application of these layers,
10 the working area of a conventional electrochemical test strip is typically about 100 μm thicker than the non-working area, which contains the electrode tracks and, typically, a dielectric layer. A stack of 100 test strips will therefore be about 10 mm thicker in the working area
15 than in the non-working area. In a test strip in accordance with the present invention, at least a part of the non-working area may be made thicker by any suitable means. Suitable means include, for example: a printed relief ink; an applied pad or tape; embossing of the base
20 layer or an intermediate layer; or an extension of the mesh layer from the working area.

The invention also provides a test device which uses the test members. Accordingly, another aspect of the
25 invention provides a test device for testing of analyte concentration in a fluid to be applied thereto, the device including a plurality of test members arranged in at least one stack, each of said test members carrying reagent means for producing an electrical signal or a colour
30 change in response to the concentration of analyte in an applied fluid; wherein each of the said test members comprises a base member having a working area to which the

fluid is to be applied, containing the said reagent means,
and a non-working area adjacent to the working area,
wherein the total thickness of each test member in at
least a portion of the non-working area is at least as
5 great as the total thickness of each test member in the
working area.

The test members may be held under a compressive load by
spring means.

BRIEF DESCRIPTION OF THE DRAWINGS

The invention will now be further described, by way of example, with reference to the following drawing in which:

5

Figure 1 is a top plan view of a test strip in accordance with the present invention.

DETAILED DESCRIPTION

10

The exemplified test strip comprises a planar base member 2, in this example of poly(butylene terephthalate) (PBT) (Valox® FR-1 from GE Plastics). The strip is 30 mm x 5.5 mm, and 0.5 mm thick. A working area 4 is of conventional construction, comprising a plurality of electrodes, a reagent layer in intimate contact with the electrodes, and a mesh layer for spreading out a drop of fluid to be received on the working area. Electrode tracks 12, for example of carbon, in the non-working area 8 of the test strip are connected to the electrodes in the working area 4 in known manner. Also in known manner, a dielectric layer 6 is printed around the working area 4 so as to overlie a portion of the electrode tracks 12, leaving just the ends of the tracks exposed for connection to corresponding electrodes on a meter. The layers are applied to the base member as inks, by screen printing. Each ink layer is about 10 to 20 μm thick, and the mesh is about 59 to 67 μm thick. The working area 4 has a total thickness which is about 100 μm thicker than the non-working area 8 up to the dielectric layer 6.

25

30

To increase the thickness of parts of the non-working

area, a high relief ink 10 has been printed in four strips. The high relief ink has a dried thickness such that the total thickness of the non-working area to which the high relief ink 10 has been applied is slightly greater than the total thickness of the test strip in the working area 4. Thus, when a stack of such test strips is formed, and a compressive load is applied to the stack by a spring, the working area 4 will not bear all the compressive load. If the test strips are used in a device which requires one strip to be slid out before being used to test analyte concentration in a fluid, scuffing of the test area will be reduced compared to a conventional test strip in which the working area stands proud of the non-working area.

15 Although the invention has been illustrated with reference to the use of a high relief ink printed in strips, it will be understood that it is not limited to this embodiment. The ink could be printed as a continuous block, and it could entirely surround the working area if desired. 20 Instead of, or in addition to, the high relief ink, other means could also be provided to increase the thickness of the non-working area, for example: an applied pad or tape; embossing of the base layer or an intermediate layer; or 25 an extension of the mesh layer from the working area into the non-working area.

CLAIMS

1. A test member suitable for use in a test device for testing of analyte concentration in a fluid to be applied thereto, the test member comprising a base member having a working area to which the fluid is to be applied, containing a reagent which is reactive to the said analyte to produce an electrical signal or a colour change, and a non-working area adjacent to the working area, wherein the total thickness of the test member in at least a portion of the non-working area is at least as great as the total thickness of the test member in the working area.
2. A test member as claimed in claim 1, wherein the total thickness of the test member in at least a part of the non-working area is greater than the total thickness of the test member in the working area.
3. A test member as claimed in claim 2, wherein the total thickness of the test member in at least a part of the non-working area is from 1 to 20 μm greater than the total thickness of the test member in the working area.
4. A test member as claimed in claim 2, wherein the total thickness of the test member in at least a part of the non-working area is from 5 to 10 μm greater than the total thickness of the test member in the working area.
5. A test member as claimed in any one of the preceding claims wherein the said at least a part of the non-working area includes a printed ink layer.

6. A test member as claimed in any one of the preceding claims wherein the said at least a part of the non-working area includes an adhered tape or pad.
- 5 7. A test member as claimed in any one of the preceding claims wherein the said at least a part of the non-working area includes an embossed structure.
8. A test member as claimed in any one of the preceding
10 claims wherein the said at least a part of the non-working area includes a mesh layer.
9. A test member as claimed in claim 8, wherein the said
15 mesh layer is continuous with a mesh layer in the working area.
10. A test member as claimed in any one of the preceding claims, wherein the said reagent produces an electrical signal in response to the concentration of analyte in an
20 applied fluid, the test member having a plurality of electrode tracks for transmitting the electrical signal, the said electrode tracks being exposed on a portion of the non-working area for connection to corresponding electrodes of a meter of a test device.
- 25 11. A test member as claimed in any one of the preceding claims, wherein the test member is an elongate test strip.
12. A test member as claimed in any one of the preceding
30 claims, suitable for use in testing for the concentration of glucose in blood.

- 10 -

13. A test member suitable for use in a test device for testing of analyte concentration in a fluid to be applied thereto substantially as herein described with reference to the drawing.

5

14. A test device for testing of analyte concentration in a fluid to be applied thereto, the device including a plurality of test members arranged in at least one stack, each of said test members carrying reagent means for
10 producing an electrical signal or a colour change in response to the concentration of analyte in an applied fluid; wherein each of the said test members comprises a base member having a working area to which the fluid is to be applied, containing the said reagent means, and a non-
15 working area adjacent to the working area, wherein the total thickness of each test member in at least a portion of the non-working area is at least as great as the total thickness of each test member in the working area.

20 15. A test device as claimed in claim 14, wherein the at least one stack of test members is held under a compressive load by spring means.

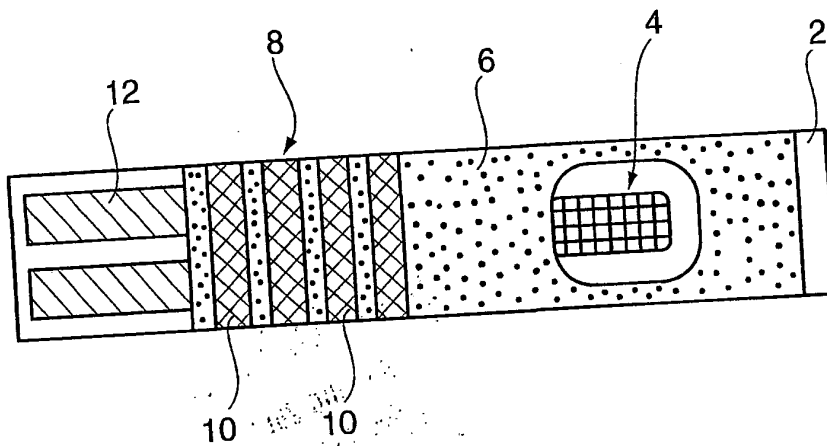

Fig. 1

INTERNATIONAL SEARCH REPORT

International Application No
PCT/JP 01/03208

A. CLASSIFICATION OF SUBJECT MATTER IPC 7 G01N33/487		
According to International Patent Classification (IPC) or to both national classification and IPC		
B. FIELDS SEARCHED		
Minimum documentation searched (classification system followed by classification symbols) IPC 7 G01N		
Documentation searched other than minimum documentation to the extent that such documents are included in the fields searched		
Electronic data base consulted during the international search (name of data base and, where practical, search terms used) EPO-Internal		
C. DOCUMENTS CONSIDERED TO BE RELEVANT		
Category *	Citation of document, with indication, where appropriate, of the relevant passages	Relevant to claim No.
X	EP 0 474 145 A (KYOTO DAIICHI KAGAKU KK) 11 March 1992 (1992-03-11) column 3, line 56 -column 4, line 7; figures 5B,7,8	1,2,6, 11,14,15
Y	---	7
X	WO 99 13101 A (ABBOTT LAB) 18 March 1999 (1999-03-18) page 6, line 31 -page 9, line 29; figures 1,2	1,2,6, 10-12
Y	---	7
Y	EP 0 785 433 A (BIO MERIEUX VITEK INC) 23 July 1997 (1997-07-23) column 9, line 54 -column 10, line 14; claims 16,17	7
	-/--	
<input checked="" type="checkbox"/> Further documents are listed in the continuation of box C.		
<input checked="" type="checkbox"/> Patent family members are listed in annex.		
* Special categories of cited documents:		
A document defining the general state of the art which is not considered to be of particular relevance *E* earlier document but published on or after the international filing date *L* document which may throw doubts on priority claim(s) or which is cited to establish the publication date of another citation or other special reason (as specified) *O* document referring to an oral disclosure, use, exhibition or other means *P* document published prior to the international filing date but later than the priority date claimed		
T later document published after the international filing date or priority date and not in conflict with the application but cited to understand the principle or theory underlying the invention *X* document of particular relevance; the claimed invention cannot be considered novel or cannot be considered to involve an inventive step when the document is taken alone *Y* document of particular relevance; the claimed invention cannot be considered to involve an inventive step when the document is combined with one or more other such documents, such combination being obvious to a person skilled in the art. *Z* document member of the same patent family		
Date of the actual completion of the international search 23 November 2001		Date of mailing of the international search report 04/12/2001
Name and mailing address of the ISA European Patent Office, P.B. 5818 Patentlaan 2 NL - 2280 HV Rijswijk Tel. (+31-70) 340-2040, Tx. 31 651 epo nl, Fax: (+31-70) 340-3016		Authorized officer * Hocquet, A

INTERNATIONAL SEARCH REPORT

International Application No
 FUJI/GB 01/03208

C.(Continuation) DOCUMENTS CONSIDERED TO BE RELEVANT		Relevant to claim No.
Category *	Citation of document, with indication, where appropriate, of the relevant passages	
A	GB 2 328 023 A (UNIV MANCHESTER) 10 February 1999 (1999-02-10) page 10, line 16 - line 17	1
A	page 7, line 1 - line 18	3,4
A	EP 0 159 727 A (FUJI PHOTO FILM CO LTD) 30 October 1985 (1985-10-30) page 12, line 29 - line 35	3-5
A	WO 94 10558 A (ENVIROMED PLC ;FRIEDLANDER URI (GB); HIGGINS IRVING JOHN (GB); COS) 11 May 1994 (1994-05-11) cited in the application page 3, last paragraph -page 4, paragraph 3	1-15

FURTHER INFORMATION CONTINUED FROM PCT/ISA/ 210

Continuation of Box I.2

Claims Nos.: 13

Rule 6.2(a) PCT

The applicant's attention is drawn to the fact that claims, or parts of claims, relating to inventions in respect of which no international search report has been established need not be the subject of an international preliminary examination (Rule 66.1(e) PCT). The applicant is advised that the EPO policy when acting as an International Preliminary Examining Authority is normally not to carry out a preliminary examination on matter which has not been searched. This is the case irrespective of whether or not the claims are amended following receipt of the search report or during any Chapter II procedure.

INTERNATIONAL SEARCH REPORT

Information on patent family members

International Application No

PCT/GB 01/03208

Patent document cited in search report	Publication date	Patent family member(s)	Publication date	
EP 0474145	A	11-03-1992	JP 2543243 B2	16-10-1996
			JP 4115160 A	16-04-1992
			EP 0474145 A2	11-03-1992
			US 5270006 A	14-12-1993
WO 9913101	A	18-03-1999	US 6129823 A	10-10-2000
			AU 9129998 A	29-03-1999
			BR 9812016 A	26-09-2000
			EP 1009850 A1	21-06-2000
			JP 2001516040 T	25-09-2001
			WO 9913101 A1	18-03-1999
EP 0785433	A	23-07-1997	US 5766553 A	16-06-1998
			AU 719926 B2	18-05-2000
			AU 5207898 A	12-03-1998
			AU 686503 B2	05-02-1998
			AU 5215496 A	24-07-1997
			BR 9602273 A	27-10-1998
			CA 2176678 A1	18-07-1997
			EP 0785433 A2	23-07-1997
			IL 118276 A	31-12-1999
			JP 2813333 B2	22-10-1998
			JP 9196852 A	31-07-1997
			KR 171259 B1	15-05-1999
			US 6045758 A	04-04-2000
			US 5843380 A	01-12-1998
GB 2328023	A	10-02-1999	AU 8636098 A	01-03-1999
			WO 9907878 A1	18-02-1999
EP 0159727	A	30-10-1985	JP 1797716 C	28-10-1993
			JP 5008383 B	02-02-1993
			JP 60230063 A	15-11-1985
			JP 1797717 C	28-10-1993
			JP 5008384 B	02-02-1993
			JP 60230064 A	15-11-1985
			JP 1799049 C	12-11-1993
			JP 5008784 B	03-02-1993
			JP 61096466 A	15-05-1986
			DE 3583414 D1	14-08-1991
			DE 3587159 D1	15-04-1993
			DE 3587159 T2	19-08-1993
			EP 0159727 A2	30-10-1985
			EP 0160916 A2	13-11-1985
			US 4855108 A	08-08-1989
			US 4950454 A	21-08-1990
WO 9410558	A	11-05-1994	AU 5374594 A	24-05-1994
			EP 0667956 A1	23-08-1995
			WO 9410558 A1	11-05-1994